

BASIC INFORMATION

Straumann® Variobase®
and Straumann® Variobase® XC



CONTENTS

1. GENERAL INFORMATION	4
1.1 Purpose of this guide	4
1.2 Introduction to Straumann® Variobase® and Variobase® XC	5
1.3 Digital workflow options	6
1.4 Soft tissue management and gingiva height selection	9
2. LAB PROCEDURE FOR STRAUMANN® VARIOBASE® AND VARIOBASE® XC	15
2.1 Preparation	15
2.2 Design and fabrication of the prosthetic restoration – Digital workflow	19
2.3 Design and fabrication of the prosthetic restoration – Conventional workflow	21
2.4 Bonding	31
3 DENTAL PROCEDURE	37
3.1 Chair-side implant borne crown on Straumann® Variobase® C	37
3.2 Final insertion of Variobase® restorations	39
3.3 Removal of finally tightened TorcFit™ abutments	40
3.4 Removal of the TLX NT Screw-retained Abutments	41
4 PRODUCT REFERENCE LIST	42
4.1 System overview	42
4.2 Auxiliaries and instruments	50

1. GENERAL INFORMATION

1.1 PURPOSE OF THIS GUIDE

This guide was created for dental technicians and dentists working with the Straumann® Variobase® for designing screw-retained or cement-retained customized prosthetic reconstructions, such as copings, crowns, bridges or overdentures. It provides complementary step-by-step information on working with the Straumann® Variobase®.

Note:

Implant-borne superstructures require optimal oral hygiene on the part of the patient. This must be considered by all involved parties when planning and designing the restoration.

For further information on indications and contraindications of Straumann® implants, such as the required minimum number of implants, implant type, diameter and loading protocols, please refer to the following documents:

- *Straumann® synOcta® Prosthetic System, Basic Information (702163/en)*
- *Straumann® Dental Implant System, Basic Information (702084/en)*
- *Straumann BLX™ Implant System, Basic Information (702115/en)*
- *Straumann TLX™ Implant System, Basic Information (702854/en)*
- *Straumann® Variobase® C, Instructions for Use (valid only outside US) (701719)*
- *Straumann® Variobase® abutments, Instructions for use (701593)*
- *Straumann iEXCEL™ Surgical Procedure, Basic information (707743/en)*
- *Straumann iEXCEL™ Prosthetic procedure, Basic information (707774/en)*

1.2 INTRODUCTION TO STRAUMANN® VARIOBASE® AND VARIOBASE® XC

Straumann® Variobase® offers a variety of treatment options for customized single, multi-tooth and full-arch prosthetic restorations. It brings efficiency by giving dental professionals a choice between the preferred in-lab or chair-side workflow to fabricate the implant restoration. Additionally, Variobase® provides the benefit of the original Straumann® implant connection.

The table below shows exemplary Variobase® and Variobase® XC portfolio. The entire portfolio is listed under section 4.1 *System overview*.

Straumann® Variobase®	Single unit restorations		<p>Variobase® for Crown</p> <ul style="list-style-type: none"> • Available for Tissue Level and Bone Level Implant system • For Variobase® with TorcFit™ connection, possibility to tailor the 5.5 mm abutment down to 3.5 mm • For CrossFit™ connection, gingiva heights available: 1 mm, 2 mm, 3 mm • For TorcFit™ connection, gingiva heights available: 0.75 mm, 1.5 mm, 2.5 mm and 3.5 mm • SC Variobase® for Crown specifically developed for the 2.9 mm implant system
			<p>Variobase® for Crown AS</p> <ul style="list-style-type: none"> • Screw channel angulation of up to 25° • Available for Tissue Level and Bone Level platforms • For Variobase® with TorcFit™ connection, possibility to tailor the 5.5 mm abutment down to 3.5 mm
			<p>Variobase® C</p> <ul style="list-style-type: none"> • Available for Tissue Level and Bone Level platforms • Integrated in Sirona®'s software libraries • Chimney design matches the shape of Sirona®'s scanbodies and pre-fabricated screw channel in material blocks
	Multi-unit and full-arch restorations		<p>Variobase® for Bridge/Bar Cylindrical</p> <ul style="list-style-type: none"> • Available for Tissue Level and Bone Level platforms and abutment level • Non-engaging conical shape to the implant <p>Note: The Variobase® XC line is available for Crown and Bridge/Bar Coping for Screw-retained abutments with a diameter 4.6 mm.</p>
	Single and multi-unit restorations		<p>Variobase® XC</p> <ul style="list-style-type: none"> • Available for TorcFit™ Bone Level and Tissue Level Implant system • Available only for TorcFit™ connection • Cuttable chimney of 7 mm down to 3.5 mm* • Gingiva heights available from 0.75 mm to 3.5 mm <p>*Please see section 2.1 <i>Preparation: Overview (table of Variobase® XC cuttability)</i>.</p>

1.3 DIGITAL WORKFLOW OPTIONS

1.3.1 Digitally produced restorations

Straumann® CARES® for dental labs and dentists provides validated, digital workflows, from scan to manufacture, delivering the flexible solutions you require. Digitally produced restorations on Straumann® Variobase® prosthetic components are accessible through a variety of offerings.

For more detailed information, please see the following brochures:

- *Straumann® CARES® Scan & Shape Basic Information (702168/en)*
- *Straumann® CARES® Implant-borne prosthetics Basic Information (702165/en)*
- *Straumann® CARES® tooth prosthetic procedures, Basic Information (702086/en)*
- *CARES® X-Stream™ Restorative Options (490.369/en)*
- *Straumann® CARES® Digital for dental labs Playing together seamlessly (490.127/en)*

1.3.1.1 CARES®, CARES® X-Stream™



With Straumann® CARES® you can simply access the desired Variobase® prosthetic components to accurately design the prosthetic restoration. In the CARES® Visual Software, the Variobase® Implant Kit is already implemented to facilitate the precise design of the interface between the Variobase® prosthetic component and the relevant prosthetic restoration (coping, crown, bridge, over-denture). Straumann's precisely milled, high-quality prosthetics cover a leading range of materials and applications for centralized, in-lab or chair-side milling.



CARES® X-Stream™

The one-step prosthetic solution: 1 scan, 1 design, 1 delivery

CARES® X-Stream™ is an innovative example of an efficient digital workflow. With only one scan and one simultaneous and adaptive prosthetic element design, all required prosthetic components (e.g. Variobase® and its relevant crown or bridge) are manufactured in the Straumann validated environment and arrive together in one delivery with an excellent fit of the components. This optimization of the necessary processing steps reduces turnaround time and related costs considerably.

CARES® X-Stream™ restorative options

For Variobase® prosthetic components a variety of restorative materials are available within CARES® X-Stream™ workflow. For more detailed information on the availability of CARES® X-Stream™ on Variobase® prosthetic components please refer to the Straumann website.

1.3.1.2 Connectivity to third-party systems

Connect your existing CAD software and mill the restoration on a Variobase® prosthetic component either via Straumann® centralized milling facilities or with your in-house milling equipment.

Our connectivity offering to third-party systems comprises two options:

1. Connectivity to our Straumann® Centralized Milling facilities

If you work with Dental Wings® or 3Shape® CAD software, the Variobase® Implant Kit is available to send the files for the prosthetic restoration to Straumann® Centralized Milling. To facilitate the precise design of the interface between the Variobase® prosthetic component and the relevant prosthetic restoration (coping, crown, bridge, overdenture) the Implant Kit is either already available in the software, or the respective files can be downloaded from the Straumann website.

Dental Wings®	CARES® Plug-in
3Shape®	DME files
Exocad	Exocad Libraries

2. Connectivity for in-house milling

For in-house milling of the prosthetic restoration on Variobase®, we offer STL files for Variobase® prosthetic components on the Straumann website for download.

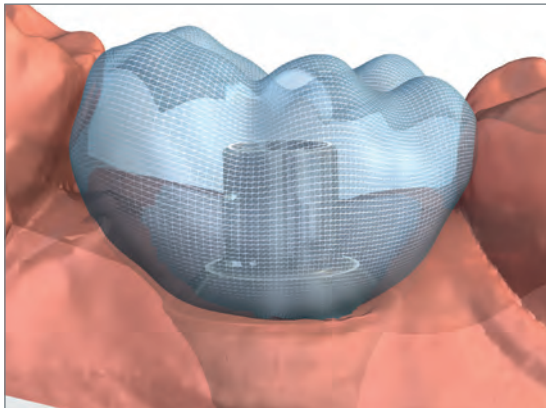

The implant kits are available for several Variobase® prosthetic components, facilitating the precise design of the interface between the Variobase® prosthetic component and the relevant prosthetic restoration (coping, crown, bridge, overdenture). It consists of an open STL file containing the required milling template for the inner geometry of the prosthetic restoration.

For more detailed information on the availability of the Straumann® Variobase® prosthetic components in third-party systems please refer to the Straumann website and contact your software provider or software dealer for availability and eligible software versions.

Note:

- The Variobase® Implant Kit only provides the inner geometry of the prosthetic restoration for the Variobase® prosthetic components. CAM-specific parameters need to be defined by the dental laboratory according to the milling equipment manufacturer's instructions.
- Availability may differ from country to country.

Milling system

Use any milling system that has the ability to mill the precise geometry of the Variobase® prosthetic components. Precise milling of the geometry requires drills of 1 mm in diameter or smaller.

1.3.1.3 Straumann® UNIQ



Straumann® UNIQ, our premium on-demand service for custom prosthetics, is available via Straumann® AXS, our online case ordering and management portal. Either send direct through your CAD software or let our design service led by skilled dental technicians support you on-demand for all your Variobase® and other custom prosthetic needs. Whichever workflow you chose, enjoy full transparency into your case's status. Our skilled dental technicians are at your service one call or click away.

Note: Straumann® UNIQ may not be available in your country. Please contact your sales representative for details. For more detailed information, please see the brochure *Straumann UNIQ* (490.898/en).

1.3.1.4 Chair-side implant-borne restoration with third-party CAD/CAM Systems

Variobase® C is specifically designed to meet the needs of third-party CAD/CAM requirements. Variobase® C is compatible with the components used in the Sirona® CEREC® or in-Lab CAD/CAM workflow.



Note:

- Variobase® C may not be available in your country. Please contact your Straumann® country sales representative for details.
- Variobase® C may not be available in the Sirona® CEREC® or in-Lab software. Please contact your dealer for availability and eligible software.
- Follow the instructions for use of the CAD/CAM system manufacturer.

1.3.2 Conventionally produced restorations

For pressing or casting techniques, burn-out copings are available for certain Variobase® prosthetic components for easy and accurate wax-up of the prosthetic restoration.



The burn-out copings* match the dimensions of the Variobase® prosthetic components, producing an inner geometry of the prosthetic restoration with the best possible fit.

*Please note that all Burn-out Copings are not available in all countries.

1.4 SOFT TISSUE MANAGEMENT AND GINGIVA HEIGHT SELECTION

The Straumann® Bone Level Implant system (BLT,BLX and BLC) put a strong emphasis on esthetic considerations. They offer tailor-made solutions that allow for natural soft tissue shaping and maintenance for their indications. A wide-ranging portfolio of healing and temporary abutments is available.

The Bone Level Variobase® for Crown is available in 4 gingiva heights and exactly matches with the shape of the conical Straumann® healing abutments.

Select the appropriate Bone Level Variobase® and the corresponding healing abutment based on your case planning.

Please see the product reference list for detailed information on the available portfolio. For further information on soft tissue conditioning with Straumann® Bone Level please refer to brochure *Straumann® Bone Level Implant line* (152.533/en) and *Straumann iExcel™ Surgical Procedure* (707743/en).

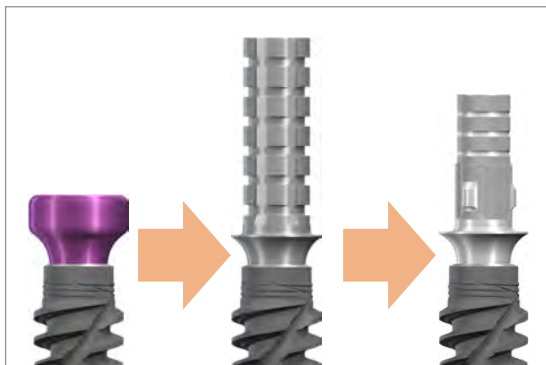

























Platform	SC				NC			RC		
Gingiva height	GH 1 mm	GH 2 mm	GH 3 mm		GH 1 mm	GH 2 mm	GH 3 mm	GH 1 mm	GH 2 mm	GH 3 mm
Healing abutments	 024.00075	 024.00085	 024.00095	 024.00105	 024.22425	 024.22225	 024.22245	 024.42225	 024.42245	 024.42265
Variobase® for Crown	 022.0038	 022.0039	 022.0040		 025.2921	 022.0102	 022.0104	 025.4921	 022.0103	 022.0105
					 022.0027	 022.0106	 022.0108	 022.0026	 022.0107	 022.0109

Platform	RB/WB						WB				
Platform diameter	Ø3.8 mm		Ø4.5 mm		Ø5.5 mm		Ø6.5 mm				
Gingiva height	GH 1.5 mm	GH 2.5 mm	GH 3.5 mm	GH 1.5 mm	GH 2.5 mm	GH 3.5 mm	GH 0.75 mm	GH 1.5 mm	GH 2.5 mm	GH 1.5 mm	GH 2.5 mm
Healing abutments	Abutment Height 2 mm								-		
	Abutment Height 4 mm								-		
Anatomic healing abutments			-			-					
Variobase® for Crown									-		
Variobase® XC for Crown*											

*Please note that Variobase® XC and Anatomic healing abutment XC (AHA) are not available in all countries.

Platform	RB/WB AS						WB AS				
Platform diameter	Ø 3.8 mm		Ø 4.5 mm			Ø 5.5 mm		Ø 6.5 mm			
Gingiva height	GH 1.5 mm	GH 2.5 mm	GH 3.5 mm	GH 1.5 mm	GH 2.5 mm	GH 3.5 mm	GH 0.75 mm	GH 1.5 mm	GH 2.5 mm	GH 1.5 mm	GH 2.5 mm
Healing abutments	Abutment Height 2 mm								-		
	064.4202S	064.4204S	064.4206S	064.4212S	064.4214S	064.4216S	064.8201S	064.8212S			
Abutment Height 4 mm									-		
064.4203S	064.4205S	064.4207S	064.4213S	064.4215S	064.4217S	064.8202S	064.8213S				
Variobase® for Crown AS	-				-			-			
062.4972							062.4971				
Variobase® XC for Crown AS*	-										
062.5009				062.5010	062.5011	062.5012	062.5013	062.5060	062.5063	062.5064	

*Please note that Variobase® XC and Anatomic Healing abutment XC (AHA) are not available in all countries.

Platform	RB/WB						WB					
Platform diameter	Ø 3.8 mm		Ø 4.5 mm		Ø 5.5 mm		Ø 6.5 mm					
Gingiva height	GH 1.5 mm	GH 2.5 mm	GH 3.5 mm	GH 1.5 mm	GH 2.5 mm	GH 3.5 mm	GH 0.75 mm	GH 1.5 mm	GH 2.5 mm	GH 1.5 mm	GH 2.5 mm	
Healing abutments	Abutment Height 2 mm		 064.42025	 064.42045	 064.42065	 064.42125	 064.42145	 064.42165	 064.82015	 064.82125	-	
	Abutment Height 4 mm		 064.42035	 064.42055	 064.42075	 064.42135	 064.42155	 064.42175	 064.82025	 064.82135		
Variobase® for B/B	-			 062.4961	-							
Variobase® XC for B/B*	 062.5065	 062.5066	 062.5067	 062.5068	 062.5069	 062.5070	 062.5071	 062.5072	-			

*Please note that Variobase® XC are not available in all countries.

Platform	RB/WB AS						WB AS					
Platform diameter	Ø 3.8 mm		Ø 4.5 mm		Ø 5.5 mm		Ø 6.5 mm					
Gingiva height	GH 1.5 mm	GH 2.5 mm	GH 3.5 mm	GH 1.5 mm	GH 2.5 mm	GH 3.5 mm	GH 0.75 mm	GH 1.5 mm	GH 2.5 mm	GH 1.5 mm	GH 2.5 mm	
Healing abutments	Abutment Height 2 mm		 064.4202S	 064.4204S	 064.4206S	 064.4212S	 064.4214S	 064.4216S	 064.8201S	 064.8212S	-	
	Abutment Height 4 mm		 064.4203S	 064.4205S	 064.4207S	 064.4213S	 064.4215S	 064.4217S	 064.8202S	 064.8213S		
Variobase® XC for B/B AS*	-			 062.5073	 062.5074	 062.5075	 062.5076	 062.5077	-			

*Please note that Variobase® XC are not available in all countries.

2. LAB PROCEDURE FOR STRAUMANN® VARIOBASE® AND VARIOBASE® XC

2.1 PREPARATION

Prerequisites

The tooth shade has been identified and noted (using color chart or digital measuring device). Both the shade information and the impression have been sent to the dental lab.

The dentist has sent either the conventional impressions as a basis for the master cast or the digital intra-oral scan to proceed with a digital model if required.

For more detailed information on digital impression options and digitally produced models, please refer to the brochures *Straumann® Scanbody, Basic information* (450.037/en) and *Straumann TLX™ Implant Impression Parts, Flow chart* (450.019/en).

Fabrication of the master cast

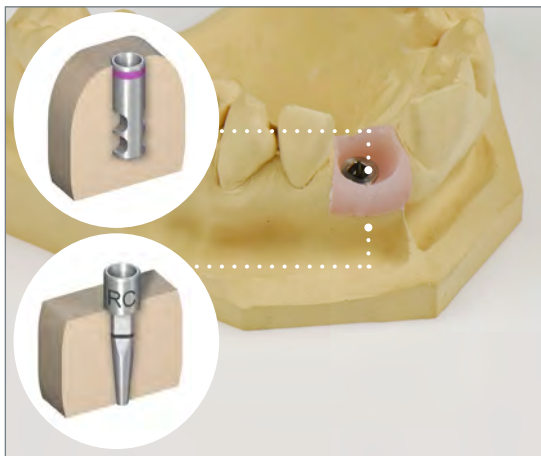

A Repositionable Implant Analog can be used for both the digital model and the master cast.

Fabricate the master cast using standard methods and type-4 dental stone (ISO 6873). To ensure high-quality restorations, consider the following requirements:

- Only use new, undamaged and original Straumann® implant analogs.
- Embed the implant analogs in the stone; the implant analogs must not move in the model.
- Always use a gingival mask to ensure the emergence profile is optimally contoured.
- Preferably use scannable material for the gingival mask.

Information of the cuttability of Variobase® XC



Variobase® XC*

The Variobase® XC offers a 7 mm abutment post-height, providing a taller option for improved bonding surface with the crown. The abutment can remain at 7 mm or be trimmed to the appropriate height based on clinical needs. Machined grooves on the post indicate the available heights: 6 mm, 5 mm, 4 mm and 3.5 mm (cuttable height of 3.5 mm is not marked by a machined groove). To maintain stability, ensure the abutment is not trimmed below the minimum cuttable level, which corresponds to the end of the cylindrical, adjustable chimney of the abutment (as shown below).

Note: Please select the correct implant kit based on the abutment post height level chosen.

Note: Please use a laboratory abutment holder or Implant analog to attach the abutment and cut on the machined groove for the desired height.

Note: Depending on the abutment platform and gingiva height, the cuttable levels may be limited. It is recommended to always follow the groove when trimming the abutment. Please consult the Overview table of Variobase® XC cuttability for the overview of the cuttability.

*Please note that Variobase® XC are not available in all countries.

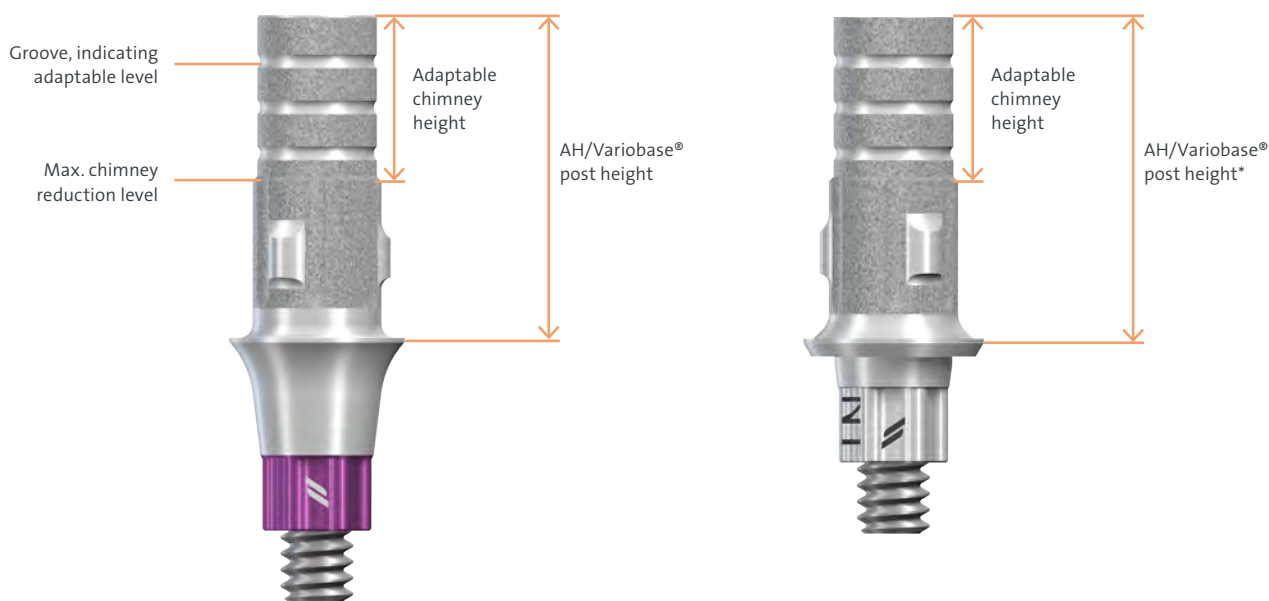

Overview table of Variobase® XC cuttability

For Variobase® XC Crown:

Platform	BLX/BLC RB/WB						BLX/BLC WB				
Platform diameter	Ø 3.8 mm			Ø 4.5 mm			Ø 5.5 mm		Ø 6.5 mm		
Gingiva height	GH 1.5 mm	GH 2.5 mm	GH 3.5 mm	GH 1.5 mm	GH 2.5 mm	GH 3.5 mm	GH 0.75 mm	GH 1.5 mm	GH 2.5 mm	GH 1.5 mm	GH 2.5 mm
Abutment post height	3.5/4/5/6/7 mm										

Platform	TLX/TLC NT	TLX/TLC RT	TLX/TLC WT
Platform diameter	Ø 3.5 mm	Ø 4.8 mm	Ø 6.5 mm
Abutment height	3.5/4/5/6/7 mm	4/5/6/7 mm	4.5/5/6/7 mm

For Variobase® XC Crown AS:

Platform	BLX/BLC RB/WB AS				BLX/BLC WB AS			
Platform diameter	Ø 4.5 mm			Ø 5.5 mm		Ø 6.5 mm		
Gingiva height	GH 1.5 mm	GH 2.5 mm	GH 3.5 mm	GH 0.75 mm	GH 1.5 mm	GH 2.5 mm	GH 1.5 mm	GH 2.5 mm
Abutment post height	5/6/7 mm	3.5/4/5/6/7 mm		6/7 mm	5/6/7 mm	3.5/4/5/6/7 mm	5/6/7 mm	3.5/4/5/6/7 mm

Platform	TLX/TLC NT	TLX/TLC RT	TLX WT
Platform diameter	Ø 3.5 mm	Ø 4.8 mm	Ø 6.5 mm
Abutment post height	6/7 mm	7 mm	7 mm

For Variobase® XC Bridge/Bar:

Platform	BLX/BLC RB/WB						BLX/BLC WB				
Platform diameter	Ø 3.8 mm			Ø 4.5 mm			Ø 5.5 mm		Ø 6.5 mm		
Gingiva height	GH 1.5 mm	GH 2.5 mm	GH 3.5 mm	GH 1.5 mm	GH 2.5 mm	GH 3.5 mm	GH 0.75 mm	GH 1.5 mm	GH 2.5 mm	GH 1.5 mm	GH 2.5 mm
Abutment post height	3.5/4/5/6/7 mm										

Platform	TLX/TLC NT	TLX/TLC RT	TLX/TLC WT
Platform diameter	Ø 3.5 mm	Ø 4.8 mm	Ø 6.5 mm
Abutment post height	3.5/4/5/6/7 mm	4/5/6/7 mm	4.5/5/6/7 mm

*Please note that Variobase® XC are not available in all countries.

For Variobase® XC Bridge/Bar AS:

Platform	BLX/BLC RB/WB AS				BLX/BLC WB AS			
Platform diameter	Ø 4.5 mm			Ø 5.5 mm		Ø 6.5 mm		
Gingiva height	GH 1.5 mm	GH 2.5 mm	GH 3.5 mm	GH 0.75 mm	GH 1.5 mm	GH 2.5 mm	GH 1.5 mm	GH 2.5 mm
Abutment post height	5/6/7 mm	3.5/4/5/6/7 mm		6/7 mm	5/6/7 mm	-		

Platform	TLX/TLC NT	TLX/TLC RT	TLX WT
Platform diameter	Ø 3.5 mm	Ø 4.8 mm	Ø 6.5 mm
Abutment post height	6/7 mm	7 mm	7 mm

*Please note that Variobase® XC are not available in all countries.

For Variobase® XC Coping:

Variobase® XC Coping type	Crown Straight	Bridge Bar Straight	Bridge Bar AS
Coping height	7 mm		7 mm
	6 mm		6 mm
	5 mm		4 mm
	4 mm		

Prerequisite for Variobase® AS where cuttability is claimed:

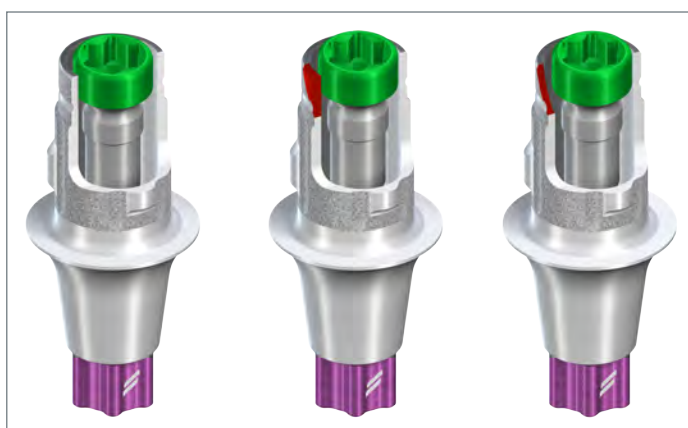

For Straumann Variobase® AS and Variobase® XC AS, when cutting down the height, the chimney might need additional modification.

This involves creating a chamfer on the cut-out window, depending on the rotational position of the restoration, to ensure there is enough clearance for screw removal.

2.2 DESIGN AND FABRICATION OF THE PROSTHETIC RESTORATION – DIGITAL WORKFLOW

The procedures explained under this section apply to the Variobase® and Variobase® XC prosthetic components.

2.2.1 Scanning and designing with scanbody

The Straumann® scanbodies represent the position and orientation of the respective dental implant or analog in CAD/CAM scanning procedures. This helps the CAD/CAM software to correctly align the subsequent CAD/CAM restoration.

Note: The Straumann® scanbodies can be reused up to 100 times. Make sure the stability of the dental implant is sufficient to support the screwing / unscrewing operations of the scanbodies. Scan spray is not required at any time.

Import the Straumann® Variobase® Implant Kit into the design software according to the software manufacturer's instructions if not already available in the respective design software.

For more detailed information on Straumann® scanbodies please refer to the brochure 702063/en and *Straumann® Scanbody* (450.037/en).



Step 1 – Assembling

- Check for proper fit of the scanbody in the analog and hand-tighten the self-retaining screw (maximum 15 Ncm).
- Only use the Straumann® SCS Screwdriver to fix the post in the analog.
- Check again for proper fit and for any rotational or vertical laxity.
- If a single-tooth restoration is planned, orient the angled surface of the scanbody buccally (not adjacent to the approximal tooth).
- Avoid any contact between the scanbody and the proximal teeth.

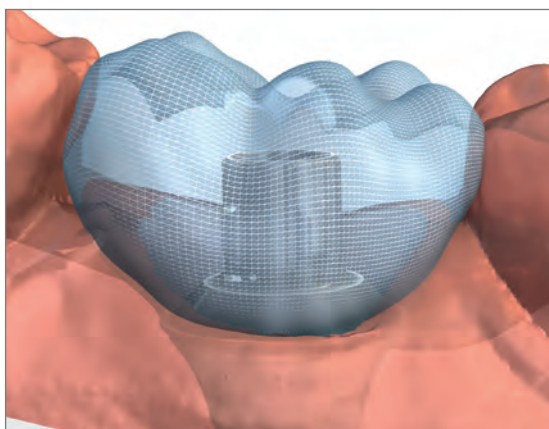

Step 2 – Scanning and modeling

- If you use third-party CAD software, follow the software provider's instructions on how to scan and recognize the scanbody.
- In CARES® Visual the scanbody matching process has already occurred.
- Model the coping or crown following the software provider's instructions.

Note: Please select the correct implant kit based on the abutment post height level chosen.

2.2.2 Milling

Step 1 – Preparation for milling

Transfer your design data to your milling machine following the instructions of your CAD software and milling equipment provider.

Note:

- Use the proper settings for the material following the instructions of your CAM software and milling equipment provider.
- Use a drill with a maximum diameter of 1 mm to precisely mill the four cams of the engaging mechanism of the Variobase® for Crown.

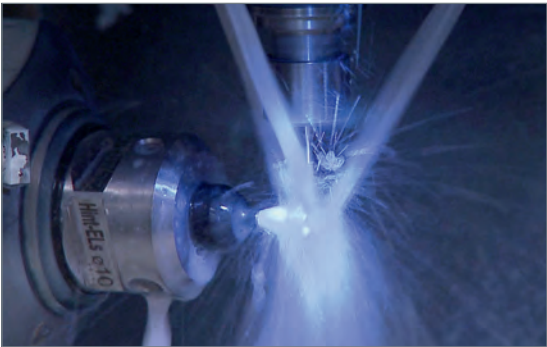

Step 2 – Milling

Mill the prosthetic restoration according to the instructions of your milling equipment provider.

2.3 DESIGN AND FABRICATION OF THE PROSTHETIC RESTORATION – CONVENTIONAL WORKFLOW

Working with the Burn-out Coping supports a clean and sharp-edged finish of the screw channel and a good fit of the prosthetic restoration with the Variobase® prosthetic components.

2.3.1 Single-unit restorations with Variobase® for Crown



Step 1 – Placing the Variobase® for Crown on the master cast

Place the Variobase® for Crown on the model analog hand-tight (maximum 15 Ncm).

Note:

- Only use the Straumann® SCS Screwdriver to fix the abutment in the analog.
- Check again for proper fit and for any rotational or vertical movement when using the Variobase® for Crown.



- If a Variobase® for Crown with adjustable chimney is used, you can customize the chimney according to the anatomical situation, but not lower than the mark to assure the abutment stability.



- When using Variobase® XC, please ensure you use the dedicated burn-out coping, which allows you to customize the height.



Step 2 – Assembling and shortening the Burn-out Coping

- Attach the Burn-out Coping to the Variobase® for Crown and check for proper fit.
- With its tight fit, the Burn-out Coping for Variobase® for Crown should be free of any rotational or vertical movement.

Tip: If the Burn-out Coping fits too tight, remove and insert the Burn-out Coping to the Variobase® for Crown several times. This loosens the fit so that the wax-up design can be removed easily.

Note: For Burn-out Coping dedicated to Variobase® XC, follow the grooves indicating the height to adjust the Burn-out coping to match the abutment post height.



- Shorten the Burn-out Coping according to the individual circumstances.
- Ensure that the shortened Burn-out Coping still covers the complete metal part of the Variobase® for Crown.



Step 3 – Wax-up design

- Contour a wax-up shape according to the individual anatomical situation.

Note:

- You can make a reduced anatomical design or a full-contour design depending on the indications of the dental material used.
- Make sure that the wax layer on the abutment is sufficiently thick (at least 0.15 mm) to provide space for the Burn-out Coping to expand during heating.
- Respect the minimum wall thickness of the respective dental material used according to the manufacturer's instructions.



Step 4 – Fabrication of the prosthetic restoration

- Use standard procedure to either press or cast the prosthetic restoration.
- This can be a coping, crown, bridge or overdenture as a framework (reduced anatomical design) or a full-contour restoration (full anatomical design).

Note:

- For optimal results, it is recommended to avoid speed investment material and processes. The plastic of the Burn-out Coping requires sufficient time to completely burn out.



Optional: for cement-retained restorations

- If necessary, make an individual crown or bridge restoration as well according to the standard procedure.







- Finalize the prosthetic restoration before bonding.

Note:

- If you veneer the framework, ensure that the veneering material's thermal expansion coefficient matches the coping material's thermal expansion coefficient.

2.3.2 Single-unit restorations with Variobase® for Crown AS

For processing a cast-on or pressed ceramic restoration with Variobase® for Crown AS use only the following components, which are designed for angled screw channel solutions.

Burn-out Coping Base	Burn-out Coping Top	Screwdriver AS	Screw AS
			
Two piece Burn-out Coping for a fixed screw-channel angulation of 25°.		Dedicated screws and screwdrivers are available for Straumann® Angled Solutions. All color-coded in green.	

Note:

- Follow the instructions for use carefully to obtain the prosthetic restoration.
- Screws AS & Screwdrivers AS are not compatible with the standard SCS and Createch screws and screwdrivers.
- The Screw AS must be tightened to 35Ncm. Applying a torque >35Ncm could damage the Screw AS and make it impossible to unscrew.



Step 1 – Assembling the Burn-out Coping Base

- Attach the Burn-out Coping Base to the Variobase® for Crown AS.
- The snap-on retention indicates proper seating.

Note

- Check the alignment of the cut-out-window of both the Variobase® for Crown AS and the Burn-out Coping Base.
- Check for the proper fit and the absence of any rotational or vertical movement between the Variobase® for Crown AS and the Burn-out Coping Base.





Step 2 – Inserting the Variobase® for Crown AS on the master cast

- Screw the assembly of the Variobase® for Crown AS and the Burn-out Coping Base onto the implant analog hand-tight (max. 15Ncm).
- Use only the Screw AS and the Screwdriver AS, which are both color-coded in green.

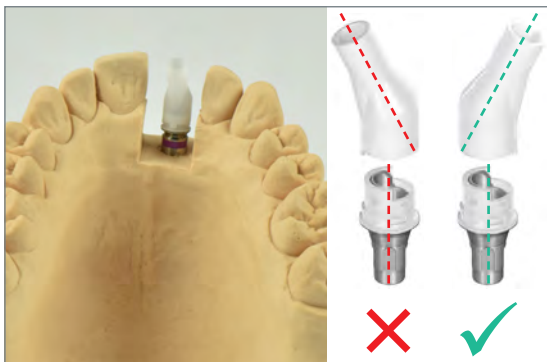

Step 3 – Assembling the Burn-out Coping

- Assemble the Burn-out Coping Top onto the Burn-out Coping Base (friction retention).
- Check that the screw channel is centered with the cut-out window of the Variobase® for Crown AS.
- Check for proper fit between the Burn-out Coping components and the Variobase® for Crown AS.



- Rotate the Burn-out Coping Top in the optimal position for the final restoration (within the $\pm 45^\circ$ rotational range).
- Wax-up together the Burn-out Coping Base and Top to avoid any rotation.

Note:

- Both the Burn-out Coping Base and Top have rotation-indexing elements to limit the rotation of the Burn-out Coping Top to a maximum of 90° around the abutment axis ($\pm 45^\circ$).
- An incorrect alignment of the Burn-out Coping Top may prevent removal of the screw after the crown is finalized.

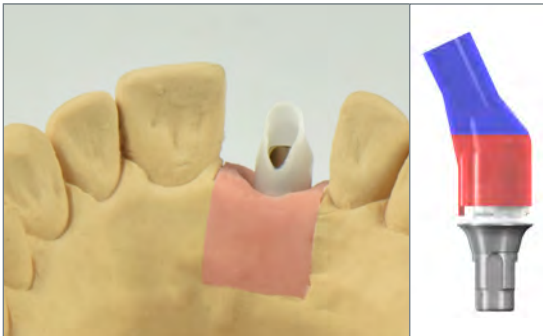

Step 4 – Modify the Burn-out Coping

- Shorten the upper part (blue area) of the Burn-out Coping Top according to the individual circumstances.
- Ensure that the shortened Burn-out Coping still covers the complete metal part of the Variobase® for Crown AS.

Note:

- Shortening the lower part (red area) of the Burn-out Coping Top may make it impossible to remove the screw.



Step 5 – Wax-up design

- Contour a wax-up shape according to the individual anatomical situation.

Note:

- You can make a reduced anatomical design or a full-contour design depending on the indications of the dental material used.
- Make sure that the wax layer on the abutment is sufficiently thick (at least 0.15 mm) to provide space for the Burn-out Coping to expand during heating.
- Respect the minimum wall thickness of the respective dental material used according to the manufacturer's instructions.



Step 6 – Fabrication of the prosthetic restoration

- Use standard procedure to either press or cast the prosthetic restoration.
- This can be an anatomically reduced or full-contour crown.
- Finalize the prosthetic restoration before bonding.

Note:

- For optimal results, it is recommended to avoid speed investment material and processes. The plastic of the Burn-out Coping requires sufficient time to completely burn out.
- If you veneer the framework, ensure that the veneering material's thermal expansion coefficient matches the coping material's thermal expansion coefficient.

2.3.3 Multi-unit restorations with Variobase® for Bridge/Bar prosthetic components

Two Variobase® for Bridge/Bar options are available for processing a multi-unit restoration or edentulous cases. Dedicated Burn-out Copings are available for the two Variobase® for Bridge/Bar prosthetic components. Please use the respective Burn-out Coping according to the following instruction.

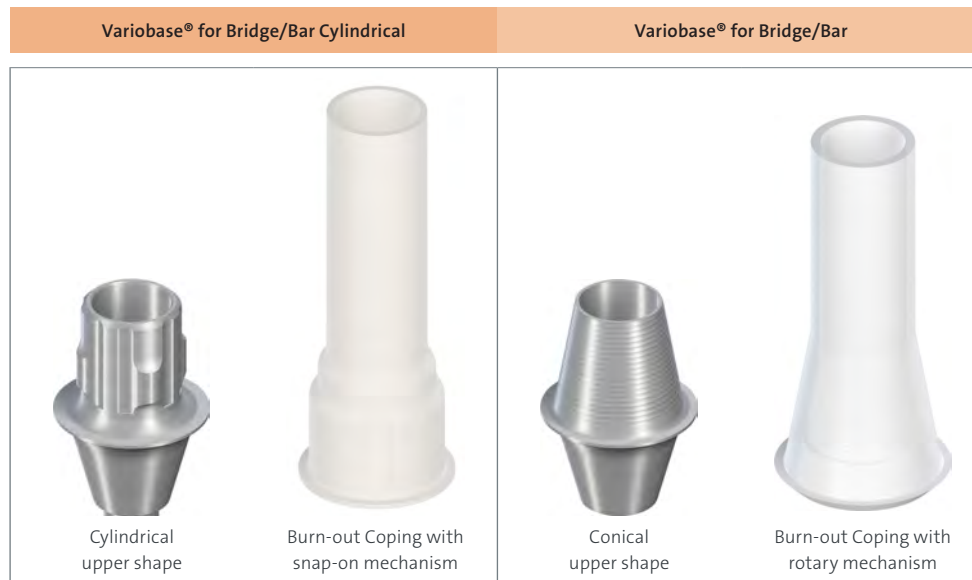

Both Variobase® for Bridge/Bar prosthetic components come with a non-engaging conical connection to the implant, which allows for compensation of up to 15 degrees of divergence per implant axis.

Variobase® for Bridge/Bar and Variobase® for Bridge/Bar Cylindrical can be used together in one restoration.



Step 1 – Placing the Variobase® for Bridge/Bar prosthetic components on the master cast

- Place the Variobase® for Bridge/Bar prosthetic components on the model analog hand-tight (max. 15 Ncm).

Note:

- Only use the Straumann® SCS Screwdriver to fix the abutment in the analog.
- Check again for proper fit and for any rotational or vertical movement when using the Variobase® for Bridge/Bar prosthetic components.



Step 2 – Assembling the Burn-out Copings

2a – Variobase® for Bridge/Bar Cylindrical

- Attach the Burn-out Coping to the Variobase® for Bridge/Bar Cylindrical and check for proper fit.

Note: The Burn-out Coping has a loose fit. Once the wax-up design is obtained, the Burn-out Coping is retained on the Variobase® for Bridge/Bar Cylindrical.



2b – Variobase® for Bridge/Bar

- Place the Burn-out Copings on the Variobase® for Bridge/Bar.
- Rotate clockwise to eliminate rotational and vertical movement.



Step 3 – Shortening the Burn-out Copings

- Shorten the Burn-out Coping according to the individual circumstances.
- Ensure that the shortened Burn-out Coping still covers the complete metal part of the Variobase® for Bridge/Bar prosthetic component.

Note: For Burn-out Coping dedicated to Variobase® XC, follow the grooves indicating the height to adjust the Burn-out coping to match the abutment post height.



Step 4 – Wax-up design

- Contour a wax-up shape according to the individual anatomical situation.

Note:

- You can make a reduced anatomical design or a full-contour design depending on the indications of the dental material used.
- Make sure that the wax layer on the abutment is sufficiently thick (at least 0.15 mm) to provide space for the Burn-out Coping to expand during heating.
- Respect the minimum wall thickness of the respective dental material used according to the manufacturer's instructions.



Step 5 – Removing the wax-up design

5a – Variobase® for Bridge/Bar Cylindrical

- Unscrew the Variobase® for Bridge/Bar Cylindrical from the implant analogs.
- Pull-off the wax-up restoration from the Variobase® for Bridge/Bar Cylindrical.

Note:

- The wax-up design should not be removed when the abutments are placed on the master cast.
- Due to the cylindrical upper shape the wax-up may be damaged.



5b – Variobase® for Bridge/Bar

- Pull-off the wax-up design from the Variobase® for Bridge/Bar with conical upper shape directly from the master cast.

Note:

- Thanks to the conical upper shape, the wax-up restoration is removed directly from the master cast as higher angulations can be compensated.



Step 6 – Fabricating the restoration

- Follow the standard procedure to either press or cast the prosthetic restoration.
- This can be a bridge or overdenture as a framework (reduced anatomical design) or a full-contour restoration (full anatomical design).

Note:

- For optimal results, it is recommended to avoid speed investment material and processes. The plastic of the Burn-out Coping requires sufficient time to completely burn out.



Note:

- If you stain and glaze the framework, ensure that the stain and glaze material's thermal expansion coefficient matches the framework material's thermal expansion coefficient.

2.4 BONDING

2.4.1 General recommendations

Pre-treatment

- Always wear gloves.
- All components must be free of grease and dry.
- Clean with steam, ultrasound or alcohol.
- Ensure a good passive fit of the restoration to obtain the best possible bonding result.

Sandblasting Variobase® prosthetic components:

Product type	Instructions
Variobase®	<ul style="list-style-type: none"> • We do not recommend sandblasting the Variobase® for Crown, Variobase® for Crown AS or Variobase® for Bridge/Bar Cylindrical to obtain a strong bond due to its specific abutment design with the retention elements. • If sandblasting is an integral part in your lab procedure, you can perform sandblasting with 50 µm AL₂O₃ and max. 2 bar. • We do not recommend sandblasting Variobase® for Bridge/Bar with conical upper shape. <p>Note: Helical thread depth may be reduced after sandblasting, potentially leading to weaker retention.</p>
Variobase® XC	It is not necessary to sandblast the Straumann® Variobase® XC, as it will alter the pre-treated abutment surface and might reduce the cement retention.
Variobase® C	The Variobase® C must be sandblasted with 50 µm AL ₂ O ₃ and max. 2 bar due to its design

Bonding material

- Use bonding material that is approved for bonding the chosen restorative material to Variobase®.
- Always use the components within a bonding system. Do not mix components with different trademarks.
- Always follow the cement manufacturer's instructions throughout the cementation procedure.
- Always use the appropriate primer if one is stated in the restorative material or cement manufacturer's instructions for use.

Note: Please refer to the instruction for use for further details on the cleaning procedure.

2.4.2 Single-unit restorations on Variobase® for Crown and Variobase® for Crown AS



Step 1 – Fixing the Variobase® prosthetic component on the master cast

- Fix the Variobase® for Crown with the SCS or Variobase® for Crown AS with the Screwdriver AS (green color-coded) to the implant analogs by tightening the basal screw or the Screw AS (green color-coded) hand-tight.
- Seal the screw channel to prevent excess cement from flowing into the screw channel.

Note:

- To ensure precise seating of the prosthetic restoration on the Variobase® for Crown or Variobase® for Crown AS, always bond on the master model.
- Due to the symmetrical nature of the four cams, confirm the position of the crown according to the actual patient anatomy prior to bonding.



Step 2 – Bonding

- Apply self-adhesive dental cement on the Variobase® for Crown or Variobase® for Crown AS.
- Follow the cement manufacturer’s instructions for use.
- Bond the prosthetic restoration to the Variobase® prosthetic component.

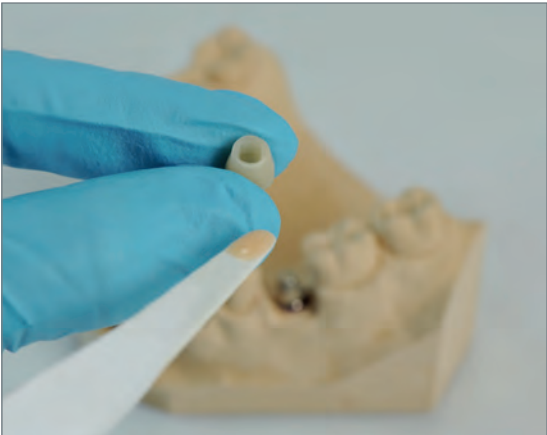

Note:

- Immediately remove excess cement from the Variobase® prosthetic component.
- Polish the lower margin of the prosthetic restoration after the cement has dried.
- Always use a polishing aid to protect the abutment’s prosthetic connection.
- Do not fire the abutment after bonding.



2.4.3 Multi-unit restorations on Variobase® for Bridge/Bar prosthetic components

2.4.3.1 Cementation procedure for Variobase® for Bridge/Bar Cylindrical in combination with Cementation Aid

To process the bonding with the Cementation Aid, please consider the following recommendations:

- The design and fabrication of the framework must be done using a Scanbody and the Variobase® for Bridge/Bar Cylindrical implant library. This ensures that the screw channel dimensions are aligned with the Cementation Aid dimensions.
- Use the Burn-out Coping for cast-on or pressed ceramic restorations to ensure that the screw channel of the restoration fits the dimensions of the Cementation Aid.
- Do not use the Cementation Aid for angled screw channel solutions.
- The Cementation Aid is for single use only.



















Step 1 – Assembling and inserting the Variobase® for Bridge/Bar Cylindrical on the master cast

- Assemble the finalized framework with the Variobase® for Bridge/Bar Cylindrical off the master cast.



- Transfer the restoration to the master cast.
- Fix the Variobase® for Bridge/Bar Cylindrical to the implant analogs by tightening the basal screws hand-tight (max. 15Ncm).
- Check for proper seating of the restoration on the master cast.
- Perform final fit check prior to bonding.
 - Check mesial/distal contact points.
 - Check passive fit.
- **Note:** Framework must sit on the abutment platform with equal load distribution after cementing. An impassive fit of the restoration may lead to de-bonding.
 - Check occlusal fit.
- Finalize (e.g. polishing, etc.) prior to cementation.

Step 2 – Choosing the appropriate Cementation Aid

	NC	RC	NNC	RN	WN	RB/WB	NT	RT	WT	Copings on Screw-retained Abutments	
Variobase® for Bridge/Bar Cylindrical	 022.0110	 022.0111	 048.377	 048.378	 048.379	 062.4961	 037.0204	 037.1204	 037.2204	 023.0027 (Ø 3.5 mm)	 023.0028 (Ø 4.6 mm)
Cementation Aid	 160.2 (CA 2)		 160.3 (CA 3)		 160.1 (CA 1)		 160.3 (CA 3)		 160.3 (CA 3)		

Note:

- The proper Cementation Aid for the respective Variobase® for Bridge/Bar Cylindrical will be included in the same packaging to ensure proper function.
- The cementation aid are not compatible with Variobase® XC portfolio.

Step 3 – Inserting the Cementation Aid and applying cement

Note: Before the Cementation Aid can be inserted, the Variobase® for Bridge/Bar Cylindrical must be screwed onto the implant analog hand-tight.

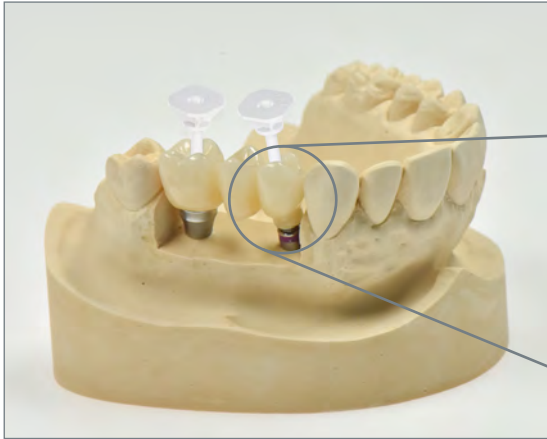

- Insert Cementation Aid into each screw channel.
- A tangible “click” indicates proper seating on the screw head.

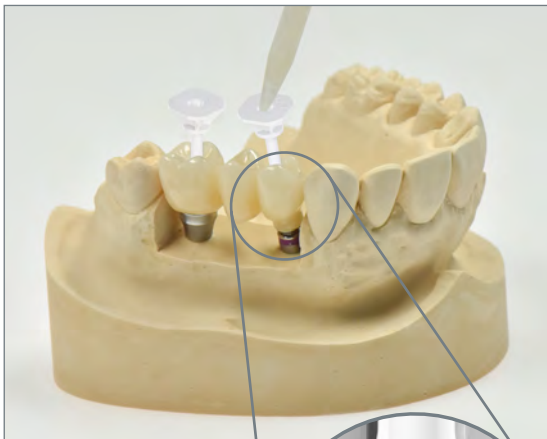

- Check the proper seating of the framework on the Variobase® for Bridge/Bar Cylindrical prior to cement application.
- Apply self-adhesive dental cement through the access hole of the Cementation Aid.
- Stop when excess cement emerges from the abutment base.

Note:

- Immediately stop applying cement and pull out the Cementation Aid if no excess cement appears on the abutment base. This indicates improper seating of the Cementation Aid.
- If any malfunction should occur use a new Cementation Aid.





- Remove the Cementation Aid after applying the cement directly.
- Immediately remove excess cement from the Variobase® prosthetic component.



- Push the restoration down and ensure proper seating of the framework on the Variobase® for Bridge/Bar Cylindrical platform.
- Harden the cement.



Step 4 – Finalization of the restoration

- Unscrew the restoration for finalization.
- Polish the lower margin of the prosthetic restoration after the cement has dried.
- Always use a polishing aid to protect the abutment's prosthetic connection.

Note:

- Do not fire the abutment after bonding.

2.4.4 Prepare restoration to send to the dentist

After finalization and cleaning, fix the restoration on the master cast before sending it to the dentist.

Make sure that the screw for final insertion was not used during lab procedure.

3 DENTAL PROCEDURE

3.1 CHAIR-SIDE IMPLANT BORNE CROWN ON STRAUMANN® VARIOBASE® C

Variobase® C is compatible with the Sirona® Scanbody, the Sirona® ScanPost® and the material blocks with a pre-fabricated screw channel, and can be used within the Sirona® CAD/CAM offering for chair-side and lab-side restorations.

















Note: For processing the prosthetic restoration, either a CEREC® system providing the option for chair-side implant borne workflow or a Sirona® in-Lab System can be used. Please follow Sirona's and the material manufacturer's instructions for use for scanning, designing, milling and finalizing the restoration.



3.1.1 Design and fabrication of the restoration

Step 1 – Ordering the components

Please select the respective parts as shown in the table below:

Variobase® C	Sirona® Scanbody size	ScanPost	Material block screw-hole size
 RC, GH 1 mm, Ø4.6 mm 022.0044	L	Sirona® ScanPost® L ¹ S BL4.1L	L
 NC, GH 1 mm, Ø3.8 mm 022.0043	S	Sirona® ScanPost® L ^{1,2} S BL3.3L2	S
 NNC, Ø3.9 mm 022.0018	S	Not available	S
 RN, Ø5 mm 022.0019	L	Sirona® ScanPost® L ³ SSO4.8L	L
 WN, Ø7 mm 022.0020	L	Sirona® ScanPost® L ³ SSO6.5L	L
 NT, Ø3.5 mm 037.0205	S	Straumann® ScanPost S RB/WB L ³ 065.0038	S
 RT, Ø4.8 mm 037.1205	L	Straumann® ScanPost S RB/WB L ³ 065.0038	L
 WT, Ø6.5 mm 037.2205	L	Straumann® ScanPost S RB/WB L ³ 065.0038	L
 RB/WB GH 1.5 mm, Ø3.8 mm 062.4981	S or L ⁴	Straumann® ScanPost S RB/WB L ³ 065.0038	S
 RB/WB GH 1.5 mm, Ø4.5 mm 062.4982	L	Straumann® ScanPost S RB/WB L ³ 065.0038	L
 RB/WB, Ø3.8 mm, GH 2.5 mm 062.5028	S	Straumann® ScanPost S RB/WB L ³ 065.0038	S
 RB/WB, Ø3.8 mm, GH 3.5 mm 062.5029	S	Straumann® ScanPost S RB/WB L ³ 065.0038	S
 RB/WB, Ø4.5 mm, GH 2.5 mm 062.5030	L	Straumann® ScanPost S RB/WB L ³ 065.0038	L
 RB/WB, Ø4.5 mm, GH 3.5 mm 062.5031	L	Straumann® ScanPost S RB/WB L ³ 065.0038	L
 WB GH 1.5 mm, Ø5.5 mm 062.4983	L	Straumann® ScanPost S RB/WB L ³ 065.0038	L
 WB, Ø5.5 mm, GH 0.75 mm 062.5032	L	Straumann® ScanPost S RB/WB L ³ 065.0038	L

¹ Please order Sirona® ScanPost® L via Sirona sales channels

² Please use Scanbody Size L when using Sirona® ScanPost® or Straumann® ScanPost S RB/WB L for scanning

³ Please order ScanPost S RB/WB L via Straumann sales channels

⁴ Please use scanbody Size S when using the Straumann® Variobase® C for scanning

Please use scanbody Size L when using the Straumann® ScanPost S RB/WB L

Note: The older versions of the Variobase® for CEREC® RC (022.0024) and NC (022.0025) are not compatible with their successors Variobase® C RC GH 1 mm (022.0044) and NC GH 1 mm (022.0043) due to different product design parameters.

Step 2 – Intra-oral scanning

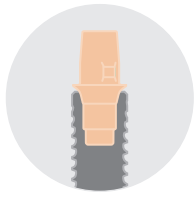

Insert Variobase® C or Sirona® ScanPost® on the implant



Place Sirona® Scanbody on Variobase® C or on Sirona® ScanPost®

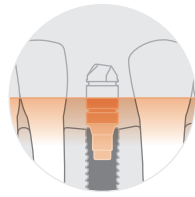

Perform intra-oral scan

Step 3 – Designing and milling the restoration

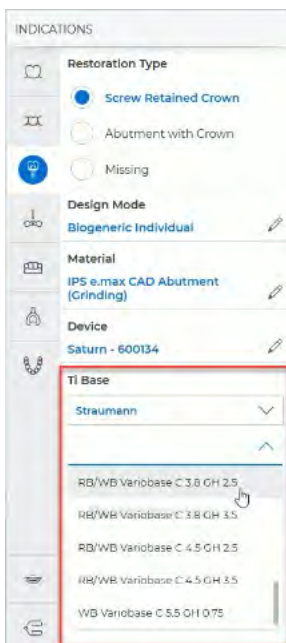

Sirona® CEREC® software selection mask

- Use your Sirona software to select the original Straumann® Variobase® C.
- Select Variobase® C from the implant library of the CAD/CAM system to design the restoration.
- Mill the restoration.

Note: Country-specific availability. Please contact your Sirona Sales Representative to check software availability or your Straumann Sales Representative to check for abutment availability.

3.1.2 Bonding

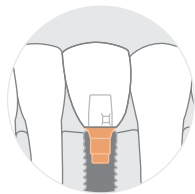

- Fit check the restoration intra-orally on the Variobase® C.
- Finish the restoration using standard procedures.
- Cement the restoration on the Variobase® C by following the instructions explained in section 2.4.2 *Single-unit restorations on Variobase® for Crown and Variobase® for Crown AS*.
- Perform final insertion in the patient's mouth.

Note: Do not fire the abutment after bonding.

3.2 FINAL INSERTION OF VARIOBASE® RESTORATIONS

Step 1 – Preparation

- Remove the healing cap or temporary restoration.
- Remove the superstructure from the master cast and unscrew the Variobase® prosthetic components from the analog.
- Thoroughly clean and dry the interior of the implant and the abutment.

Note:

- Always ensure that surfaces of threads and screw heads are clean and that a new screw is used for the final restoration.

3.2.1 Final insertion of single-unit restorations on Variobase® for Crown and Variobase® for Crown AS



Option A: Screw-retained final restoration

- Position the sterilized Variobase® prosthetic components with the prosthetic restoration in the implant. Tighten the screw to 35 Ncm using either the SCS or AS Screwdriver together with the Ratchet with Torque Control (Art. No. 046.821) or Ratchet and the Torque Control Device.
- Close the screw channel with cotton and sealing compound. This allows for later removal of the Variobase® in case a crown, bridge or overdenture replacement should be required.



Option B: Variobase® for Crown – cement-retained final restoration

- Position the sterilized Variobase® in the implant. Tighten the screw to 35 Ncm using the SCS Screwdriver together with the Ratchet with Torque Control (Art. No. 046.821) or Ratchet and the Torque Control Device.
- Close the screw channel with cotton and sealing compound. This allows for later removal of the Variobase® in case a crown replacement should be required.
- Cement the superstructure to the abutment.
- Remove excess cement.

3.2.2 Final insertion of multi-unit restorations on Variobase® for Bridge/Bar prosthetic components

- Position the sterilized Variobase® prosthetic components with the prosthetic restoration in the implant.
- Screw all abutments into the implant with light hand-tight force and equal load distribution.
- Tighten the screws with 35 Ncm diagonally to avoid friction.



Tip: This tension-free screw-in technique is very important for larger restorations or full-arch restorations on Variobase® for Bridge/Bar prosthetic components to avoid loosening of the bond.

3.3 REMOVAL OF FINALLY TIGHTENED TORCFIT™ ABUTMENTS

Due to tight sealing of the 7° taper of the TorcFit™ connection, abutments can lock strongly in the implant after final insertion.

The RB/WB Abutment Removal Screw pushes the abutment out of the implant without applying high torque or bending moments to the bone.

3.3.1 TorcFit™ Removal Tool, for Basal Screw (art. nos. 065.0008 and 065.0009)

If the basal screw can not be lifted with the SCS screwdriver after it is unscrewed [1] the Removal Tool may be used.

This tool features a left-hand thread that engages in the basal screw head [2] in order to lift the Basal Screw [3].

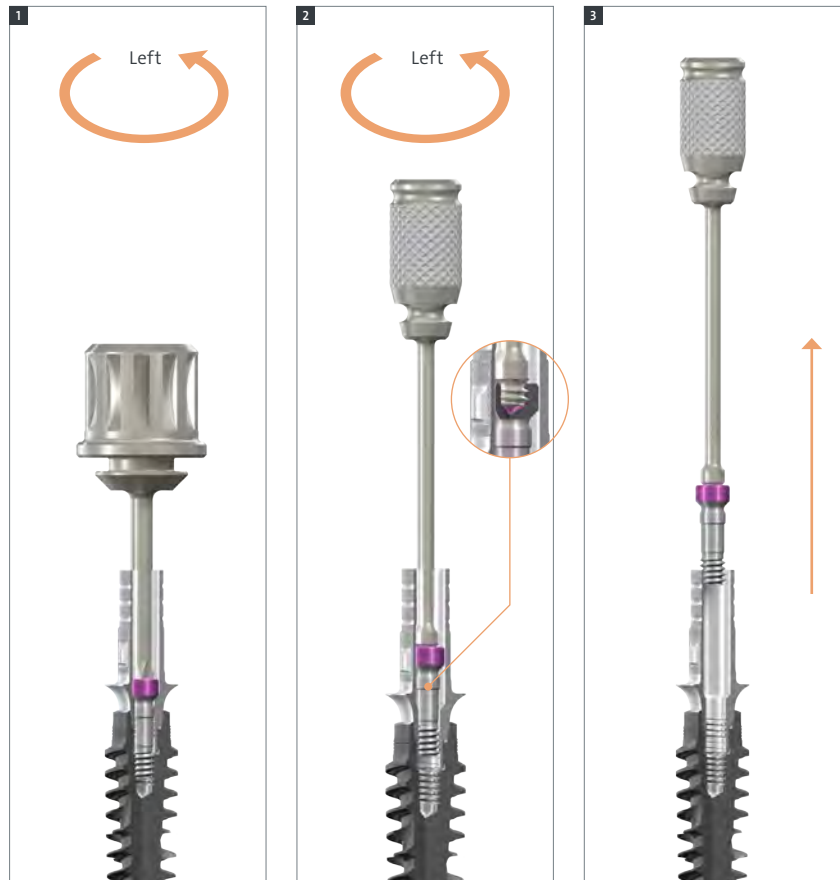

3.3.2 TorcFit™ Abutment Removal Screw (art. no. 065.007)

If the abutment can not be removed by hand due to the friction fit the Abutment Removal Screw can be used to push out the abutment.

Connect the SCS Screwdriver to the removal screw and screw it into the abutment [4] until the abutment is pushed out and can be removed [5].

Please note: When dealing with Variobase® for Crown AS, there may be a need to remove or cut the crown in order to gain access to the screw channel. Once the crown has been taken off, the process for removing the angled abutment with the removal tool remains the same as that for the straight abutment.

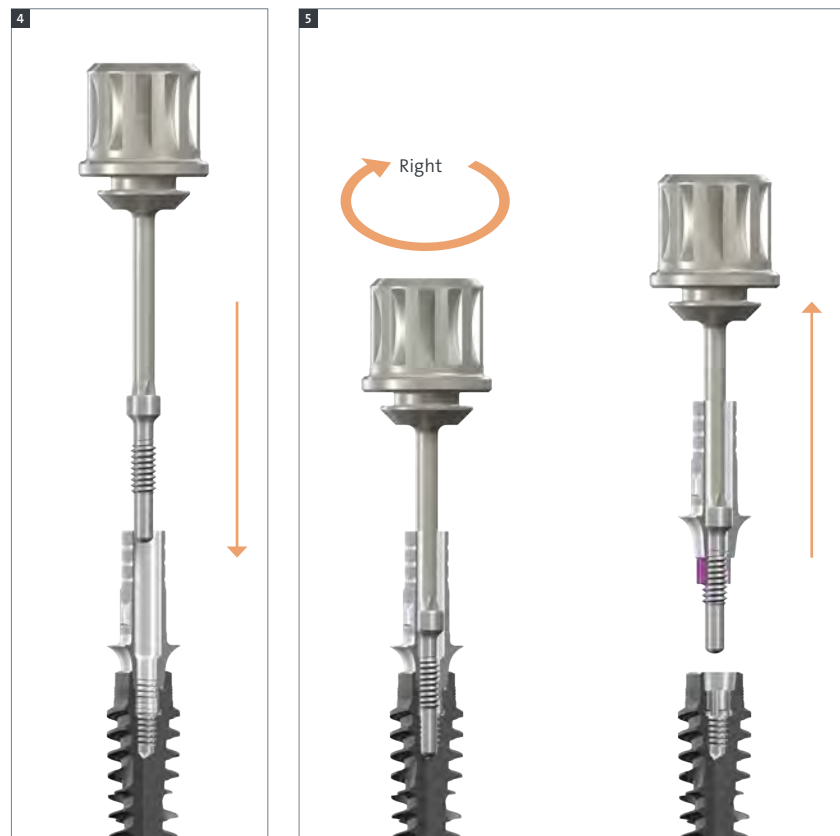

3.4 REMOVAL OF THE TLX NT SCREW-RETAINED ABUTMENTS

Due to tight sealing of the 7° conus of the TorcFit™ connection, the TLX NT Screw-retained Abutments can lock strongly in the implant after final insertion.

3.4.1 TorcFit™ Removal

Tool, for Basal Screw

(065.0008 and 065.0009)

If the basal screw cannot be removed with the SCS Screwdriver [1], the Removal Tool may be used.

This tool features a left-hand thread that engages in the basal screw head [2] to remove the Basal Screw [3].

3.4.2 TorcFit™ Abutment-Removal

Screw (065.0007)

In case the TLX NT Screw-retained Abutment cannot be removed using the SCS Screwdriver alone, the Abutment Removal Screw can be used.



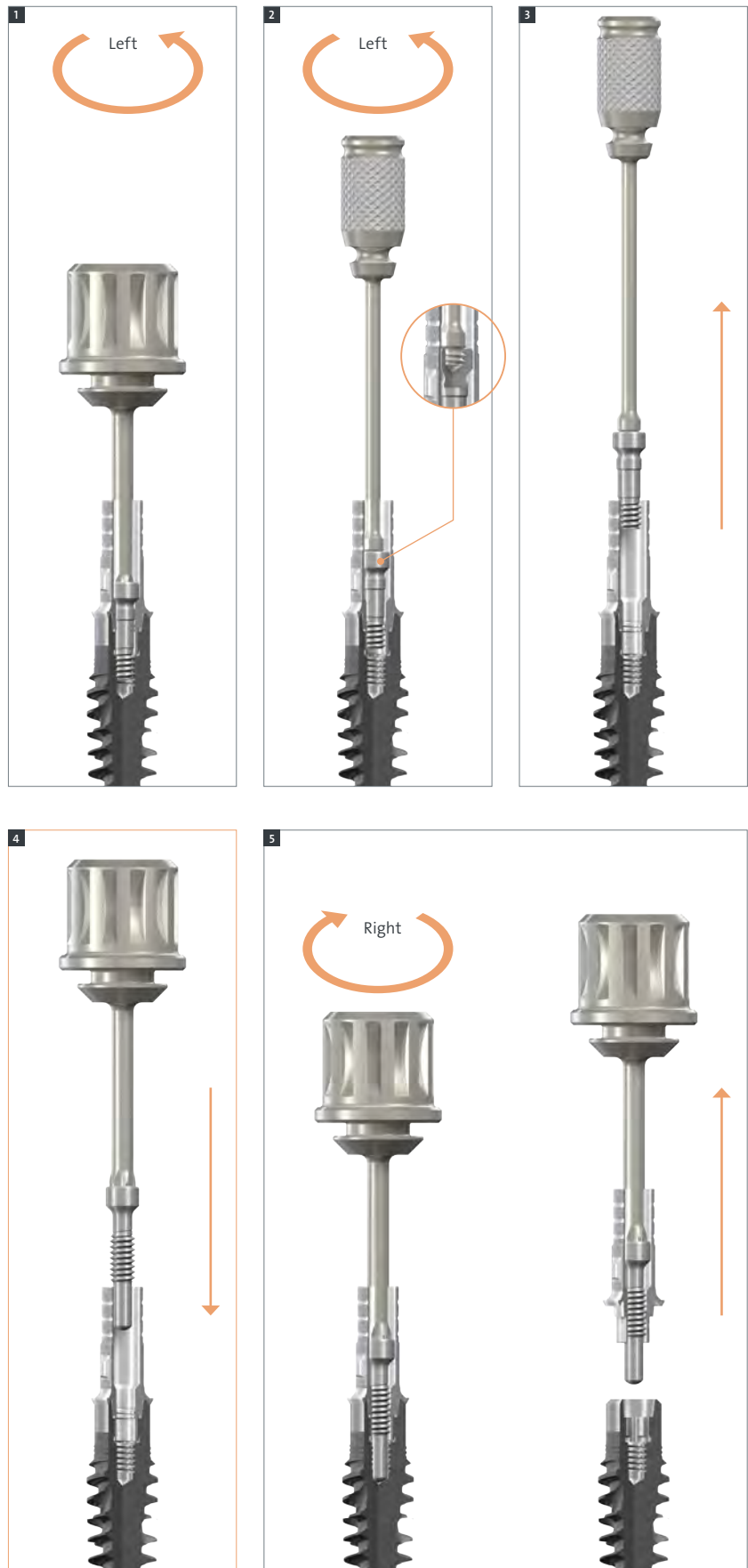





































Insert the SCS Screwdriver into the Abutment Removal Screw. Engage the screw into the abutment [4] until the grip is sufficient enough to free the abutment from the implant [5].































4 PRODUCT REFERENCE LIST













4.1 SYSTEM OVERVIEW









4.1.1 Implant Level





		SC	NC	RC	NNC	RN	WN	RB/WB		WB	
		Oval	∅3.8 mm	∅4.5 mm	∅3.9 mm	∅5.05 mm	∅7.0 mm	∅3.8 mm	∅4.5 mm	∅5.5 mm	
Analog											
		025.0023	025.2101	025.4101	048.127	048.124	048.171	065.0021 RB/WB		065.0022 WB	
Repositionable Implant Analog					-						
		025.0024	025.2102	025.4102		048.129	048.172	065.0023		065.0024	
Scanbody											
		025.0077	025.0078	025.0079	048.383	048.384	048.385	065.0103		065.0103	
Variobase® for Crown	Abutment Height 3.5 mm	Gingiva Height 1 mm									
		Gingiva Height 2 mm									
		Gingiva Height 3 mm									
	Abutment Height 5.5 mm	Gingiva Height 1 mm									
		Gingiva Height 2 mm									
		Gingiva Height 3 mm									

Variobase® XC for Crown		RB/WB		WB	
		Ø 3.8 mm	Ø 4.5 mm	Ø 5.5 mm	Ø 6.5 mm
		Gingiva Height 0.75 mm	-		 062.5023
Gingiva Height 1.5 mm	 062.5017	 062.5020	 062.5024	 062.5061	
Gingiva Height 2.5 mm	 062.5018	 062.5021	 062.5059	 062.5062	
Gingiva Height 3.5 mm	 062.5019	 062.5022	-		























		SC	NC	RC	NNC	RN	WN
		Oval	Ø4.1mm	Ø4.7mm	Ø4.2mm	Ø5.1mm	Ø7.0mm
Burn-out copings for Variobase® for Crown	Abutment Height 3.5 mm	 023.0011 023.0011V4	 023.2756 023.2756-04	 023.4759 023.4759-04	 048.267 048.267V4	 048.268 048.268V4	 048.269 048.269V4
	Abutment Height 5.5 mm	-	 023.0018 023.0018V4	 023.0017 023.0017V4	 023.0014 023.0014V4	 023.0015 023.0015V4	 023.0016 023.0016
Auxiliary Screws for Variobase® for Crown		 025.0031	 025.2900	 025.4900	 048.313	 048.356	 048.356

Variobase® for Crown AS	Abutment Height 3.5 mm	-	 022.0084	 022.0087	 048.876	 048.877	 048.878
	Abutment Height 5.5 mm		 022.0093	 022.0096	 048.879	 048.880	 048.881
Gingiva Height 1 mm	 023.0025		 023.0026	 048.896	 048.897	 048.898	
Gingiva Height 1 mm	 025.0055		 025.0055	 048.899	 048.906	 048.906	
Burn-out copings for Variobase® for Crown AS							
Auxiliary Screws for Variobase® for Crown AS							

Variobase® XC for Crown AS		RB/WB		WB	
		Ø 3.8 mm	Ø 4.5 mm	Ø 5.5 mm	Ø 6.5 mm
		Abutment Height 7 mm			 062.5012
Gingiva Height 0.75 mm		-		-	
Gingiva Height 1.5 mm		 062.5009	 062.5013	 062.5063	
Gingiva Height 2.5 mm		 062.5010	 062.5060	 062.5064	
Gingiva Height 3.5 mm		 062.5011		-	

Burn-out Coping for Variobase® XC for Crown		RB/WB		WB	
		Ø 3.8 mm	Ø 4.5 mm	Ø 5.5 mm	Ø 6.5 mm
		Abutment height 7 mm	 065.0106	 065.0107	 065.0108
Auxiliary Screws for Variobase® for Crown	 065.0036				

Burn-out Coping for Variobase® XC for Crown AS		RB/WB		WB	
		Ø 3.8 mm	Ø 4.5 mm	Ø 5.5 mm	Ø 6.5 mm
		Abutment height 7 mm		 065.0112	 065.0113
Auxiliary Screws for Variobase® for Crown	 065.0037				

	SC	NC	RC	NNC	RN	WN
	Oval	∅4.5 mm	∅4.5 mm	∅4.2 mm	∅5.0 mm	∅7.0 mm
Variobase® for Bridge/Bar Cylindrical		 022.0110	 022.0111	 048.377	 048.378	 048.379
Burn-out copings for Variobase® for Bridge/Bar Cylindrical	-	 023.0029 023.0029V4	 023.0030 023.0030V4	 048.380 048.380V4	 048.381 048.381V4	 048.382 048.382V4
Variobase® for Bridge/Bar		 022.0000	 022.0001	 022.0002	 022.0003	 022.0004
Burn-out Coping for Variobase® for Bridge/Bar	-	 023.0006 023.0006V4	 23.0007 023.0007V4	 023.0008 023.0008V4	 023.0009 023.0009V4	 023.0010 023.0010V4
Auxiliary Screws for Variobase® for Bridge/Bar and Variobase® for Bridge/Bar Cylindrical		 025.2926			 048.356	







		RB/WB			WB			
		Ø3.8 mm	Ø4.5 mm	Ø5.5 mm				
Variobase® XC for Bridge/Bar	Abutment Height 7 mm	Gingiva Height 0.75 mm	-			062.5071		
		Gingiva Height 1.5 mm				062.5072		
		Gingiva Height 2.5 mm			-			
		Gingiva Height 3.5 mm			-			
		-						
Burn-out Coping for Bridge/Bar	Abutment height 7 mm				065.0133			
Auxiliary Screws for Variobase® for B/B								
		RB/WB			WB			
		Ø3.8 mm	Ø4.5 mm	Ø5.5 mm				
Variobase® XC for Bridge/Bar AS	Abutment Height 7 mm	Gingiva Height 0.75 mm	-			062.5076		
		Gingiva Height 1.5 mm				062.5077		
		Gingiva Height 2.5 mm			-			
		Gingiva Height 3.5 mm			-			
		-						
Burn-out Coping for Bridge/Bar AS	Abutment height 7 mm			065.0135			065.0136	
Auxiliary Screws for Variobase® for B/BAS								
		RB/WB			WB			
		Ø3.8 mm	Ø4.5 mm	Ø5.5 mm				
Variobase® C	Abutment Height 7 mm	Gingiva Height 0.75 mm	-			062.5032		
		Gingiva Height 1.5 mm				062.4983		
		Gingiva Height 2.5 mm			-			
		Gingiva Height 3.5 mm			-			
		-						
Auxiliary Screws for Variobase® C								
ScanPost								







	SC	NC	RC	NNC	RN	WN
	Oval	Ø3.8 mm	Ø4.5 mm	Ø3.9 mm	Ø5.0 mm	Ø6.7 mm
Variobase® C						
		022.0043	022.0044	022.0018	022.0019	022.0020
Auxiliary Screws for Variobase® C						
		025.2900	025.4900	048.313	022.0045	022.0045
ScanPost		Sirona® ScanPost® L ¹ S BL3.3L	Sirona® ScanPost® L ¹ S BL4.1L	Not available	Sirona® ScanPost® L ¹ SSO4.8L	Sirona® ScanPost® L ¹ SSO6.5L







¹ Please order Sirona® ScanPost® L via Sirona sales channels







² Please use Scanbody Size L when using Sirona®'s ScanPost® for scanning





³ Please order ScanPost S RB/WB L via Straumann sales channels

	NT	RT	WT
	∅4 mm	∅5 mm	∅7 mm
Abutments Variobase® XC for Crown	 062.5025	 062.5026	 062.5027
Burn-out Copings for Variobase® for Crown	 065.0109	 065.0110	 065.0111
Basal Screw for Variobase® for Crown	 036.3110		

















	NT	RT	WT
	∅4 mm	∅5 mm	∅7 mm
Abutments Variobase® XC for Crown AS	 062.5014	 062.5015	 062.5016
Burn-out Copings for Variobase® XC for Crown AS	 065.0114	 065.0115	 065.0116
Basal Screw for Variobase® for Crown AS	 036.3111		

	NT	RT	WT
	∅4.2 mm	∅5 mm	∅7 mm
Abutments Variobase® XC for B/B	 062.5003	 062.5004	 062.5005
Burn-out Copings for Variobase® XC for B/B	 065.0117	 065.0118	 065.0119
Basal Screw for Variobase® for B/B	 036.3110		

	NT	RT	WT
	∅4.2 mm	∅5 mm	∅7 mm
Abutments Variobase® XC for B/B AS	 062.4992	 062.4993	 062.4994
Burn-out Copings for Variobase® XC for B/B AS	 065.0120	 065.0121	 065.0122
Basal Screw for Variobase® for B/B AS	 036.3111		

	NT	RT	WT
	∅4 mm	∅5 mm	∅7 mm
Variobase® C*	 037.0205	 037.1205	 037.2205
Sirona® Scanbody size	"S"		"L"
Material block screw-hole size	"S"		"L"
Replacement screw	 036.3110		

4.1.2 Abutment Level

		Abutment Level				
		NC	RC and RB/WB			
Analog	 <p>023.2754 (0°, Ø 3.5 mm) 023.4756 (0°, Ø 4.6 mm) 023.4757 (angled, Ø 4.6 mm)</p>	 <p>023.4756 (0°, Ø 4.6 mm) 023.4757 (angled, D 4.6 mm)</p>				
	 <p>025.0007 (Ø 3.5 mm) 025.0008 (Ø 4.6 mm)</p>	 <p>025.0008 (Ø 4.6 mm)</p>				
Scanbody	 <p>025.0080 (Ø 3.5 mm) 025.0081 (Ø 4.6 mm)</p>	 <p>025.0081 (Ø 4.6 mm)</p>				
	 <p>023.0027 (Ø 3.5 mm) 023.0028 (Ø 4.6 mm)</p>	 <p>023.0028 (Ø 4.6 mm)</p>	 <p>023.0038 (Ø 4.6 mm)</p>	 <p>023.0040 (Ø 4.6 mm)</p>	 <p>023.0041 (Ø 4.6 mm)</p>	
Burn-out copings for Variobase® for Bridge/Bar Cylindrical	 <p>023.0031; 023.0031V4 (Ø 3.5 mm) 023.0032 023.0032V4 (Ø 4.6 mm)</p>	 <p>023.0032 (Ø 4.6 mm) 023.0032V4 (Ø 4.6 mm)</p>	-			
	 <p>023.4763</p>	 <p>023.4763</p>	 <p>023.4763</p>	 <p>025.0054</p>		

4.2 AUXILIARIES AND INSTRUMENTS

Art. No.	Pictures	Article	Dimensions	Material
SCS Screwdrivers				
046.400		SCS Screwdriver for Ratchet, extra-short	Length 15 mm	stainless steel
046.401		SCS Screwdriver for Ratchet, short	Length 21 mm	stainless steel
046.402		SCS Screwdriver for Ratchet, long	Length 27 mm	stainless steel
Angled Solutions Screwdrivers				
046.786		Screwdriver AS for Ratchet, extra-short	Length 15 mm	stainless steel
046.787		Screwdriver AS for Ratchet, short	Length 21 mm	stainless steel
046.788		Screwdriver AS for Ratchet, long	Length 27 mm	stainless steel
046.789		Screwdriver AS for handpiece, extra-short	Length 20 mm	stainless steel
046.790		Screwdriver AS for handpiece, short	Length 26 mm	stainless steel
046.791		Screwdriver AS for handpiece, long	Length 32 mm	stainless steel
046.792		Screwdriver Handling Aid AS	n/a	stainless steel
Ratchet				
046.119		Ratchet, including service instrument	Length 84 mm	stainless steel
046.821		Ratchet with Torque Control	Length 97 mm	stainless steel
Polishing Aids and Analog Holder				
046.239		Analog Holder	Length 105 mm	Al/Steel
046.245		Polishing Protector for RN synOcta® Copings, transocclusal screw-retained	Length 15 mm	stainless steel
025.0029		SC Polishing Aid	Length 16 mm	stainless steel
025.2920 025.2920-04		NC Polishing Aid	Length 16 mm	stainless steel
025.4920 025.4920-04		RC Polishing Aid	Length 16 mm	stainless steel
TorFit™ Abutment Removal Tools				
065.0007		TorFit™ Abutment-Removal Screw		TAN
065.0009		TorFit™ Removal Tool, for Basal Screw, left-handed	Length 21 mm	stainless steel
065.0008		TorFit™ Removal Tool, for Basal Screw, left handed	Length 27 mm	stainless steel

International Headquarters

Institut Straumann AG
Peter Merian-Weg 12
CH-4002 Basel, Switzerland
Phone +41 (0)61 965 11 11
Fax +41 (0)61 965 11 01
www.straumann.com

Sirona® and CEREC® are registered trademarks of Sirona Dental Systems GmbH, Germany. 3Shape® is a registered trademark of 3Shape A/S. DentalWings® is a registered trademark of Dental Wings Inc., Canada.

© Institut Straumann AG, 2025. All rights reserved.

Straumann® and/or other trademarks and logos from Straumann® mentioned herein are the trademarks or registered trademarks of Straumann Holding AG and/or its affiliates. All rights reserved.

